

Made in America

Lifetime Guarantee



Thank you for purchasing this digital dash panel from Intellitronix. We value our customers!

INSTALLATION GUIDE

Five Gauge Universal Digital Dash Panel

Part Number: DP10001

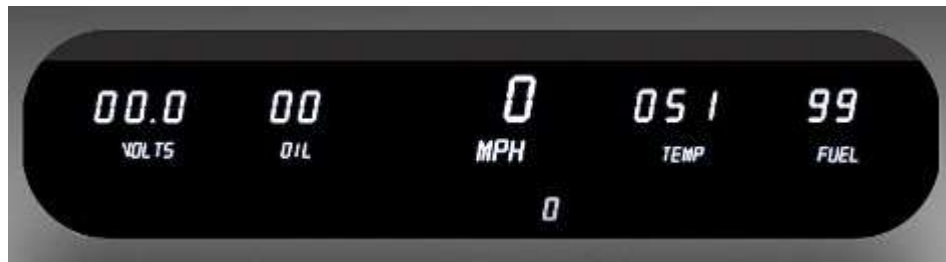

*** Always disconnect the battery before attempting any electrical work on your vehicle. ***

KIT COMPONENTS

- ◇ One (1) Digital Circuit Board
- ◇ One (1) Smoked Acrylic See -Through Lens
Peel off protective covering from both sides of lens.
- ◇ One (1) Water Temperature Sending Unit with bushing
1/8" NPT, 0-255 Deg., 1/2" NPT bushing
- ◇ One (1) Pressure Sending Unit (S8434)
1/8" NPT 0-100 PSI Oil Pressure
- ◇ One (1) Universal Speedometer Sensor (S9013)
7/8" NPT Industry Standard
- One (1) Mounting Kit
- Four (4) 4-40 x 1-1/4 Black oxide hex head screws and washers
- Four (4) Nylock nuts
- Four (4) #6-3/8 Nylon spacer

WIRING INSTRUCTIONS

Note: Automotive circuit connectors are the preferred method of connecting wires. You may solder if preferred.

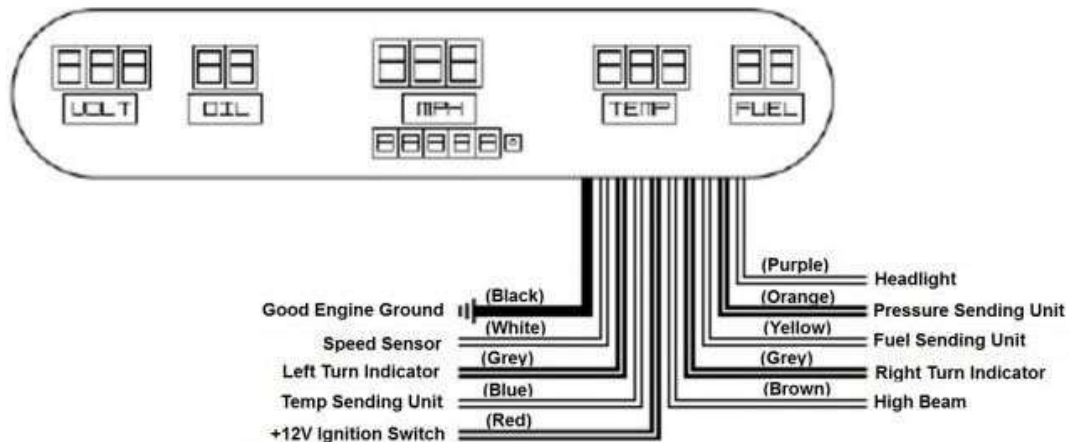

Ground - Black This is the main ground for the display system. A wire should be run from this board to the vehicle's main engine block ground. Use 18 AWG or larger wire to ensure sufficient grounding. Proper vehicle grounding is extremely important for any gauges (or electronics) to operate correctly. The engine block should have heavy ground cables to the battery, frame, and firewall. Failure to properly ground the engine block, senders, or digital dash can cause incorrect or erratic operation.

Power - Red Connect the power terminal to accessory +12V power from the fuse panel or vehicle wiring harness. This terminal should have power when the key is on or in accessory position. Use 18 AWG wire to ensure the system receives a sufficient power feed.

Dimmer - Purple Connect to the parking lights to dim the LEDs 50% when the headlights are on. However, **do not** connect to the headlight rheostat control wire; the dimming feature will not work properly.





Turn Signals - Grey Two 18-gauge wires, one for each signal. Each wire is labeled on the printed circuit board as "LEFT" and "RIGHT". Connect each wire to its corresponding indicator circuit.

High Beams - Brown Connect the brown wire to your high beam headlight.

Oil - Orange Replace the existing oil pressure sending unit with the unit included. **Do not** use Teflon tape or other sealer on the new sending unit's threads to avoid inaccurate ground connections as the sending units get their ground from the threads. The oil sender gets its grounding from the threading into the engine block, thus proper grounding is crucial. Connect the orange wire to the sending unit.

Water - Blue Replace the existing water temperature sending unit with the unit included. The gauge is incompatible with other sending units. **Do not** use Teflon tape or other sealer on the new sending unit's threads to avoid inaccurate readings. Connect the blue wire to the sending unit.

Fuel – Yellow The fuel gauge sending unit is not normally supplied because the display system can use the existing fuel level sending unit in the tank in most cases. If your wiring harness already has a single wire routed through the vehicle for the fuel sender then it may be used. If using a wire from an external harness, make sure that the wire does not have power. Fuel senders reference their ground from the sender mounting plate. Connect the yellow wire to the factory sending unit. Be sure the toggle settings on the switch match those displayed on the diagram, as illustrated.

Fuel Selector Switch Position		
Manufacturer	Switch Position	Ohm Range (Empty to Full)
Ford/ Chrysler		73-10 OHM
GM		0-90 OHM
VDO		10-180 OHM
Universal/ Stewart Warner		240-33 OHM

Both toggles in the **up** position for Ford/Chrysler

For GM - #1 toggle is up, # 2 toggle is down.

Both toggles in the **down** position for VDO

For Universal/Stewart Warner - #1 toggle is down, # 2 toggle is up.

Speedometer – White Disconnect the mechanical speedometer cable from the transmission and thread the new electronic sensor onto the transmission. This unit comes with a 3-wire sensor. If you are using this sensor, the **white** wire is the speed signal; connect this to the speed signal wire on your gauge. The **red** and **black** wires in the cable are switched power (12VDC) and ground, respectively. Twisting the ground and signal wires around each other will provide an additional level of interference protection. The speed signal wire should not be routed alongside the tachometer, ignition, or any other high-current or high-voltage wires. For vehicles which have a vehicle speed signal from a transmission -- one wire goes to the speedometer, and the other to the ground -- or ECM. Tap into the VSS wire (consult a vehicle service manual or wiring diagram to determine the correct wire color) and connect it to the white speed sending wire on the digital dash.

Note: *If your vehicle is equipped with an electronic transmission there will be an electronic vehicle sender with either two or three wires coming off of it.*

DIGITAL PERFORMANCE SPEEDOMETER

Note: *If using the Intellitronix GPS Sending Unit, (S9020 – not included) the speedometer does not need to be calibrated.*

The speedometer leaves the factory with a pre-set industry standard setting of 8,000 pulses per mile. Chances are that you may not need to recalibrate your speedometer, unless you have changed the original tire size or the rear end gear ratio.

Note: *Do not attempt to calibrate your speedometer until after it is working properly and you have determined that the speed is incorrect. The calibration procedure will NOT correct a faulty installation or improper wiring. If you attempt to recalibrate your speedometer without making sure the speedometer is receiving pulses from the sending unit, the speedometer will display 'Err' and default back to the factory settings.*

To calibrate:

1. **Locate a measured mile where you can safely start and stop your vehicle.** By running the vehicle over this measured distance, the speedometer will learn the number of pulses outputted by the speedometer sensor during a specific measured distance. It will then use this acquired data to calibrate itself for accurate reading. There is a small recall push-button in the center of the panel used to calibrate and read all of the data stored in the speedometer. After installing your speedometer according to the wiring instructions, when the ignition is on it should immediately display the default screen of **0 MPH**, if the vehicle is not moving.

NOTE: You will then need to drive your vehicle to the predetermined measured mile. During this trip, the speedometer should read something other than 0 MPH. If it does not change, return and locate the problem before continuing. Otherwise, proceed with the calibration.

2. Stop at the beginning of the measured mile with your vehicle running and in odometer mode (NOT trip mode), press and hold the push-button until the odometer displays 'HI-SP'. On its own, the gauge will then cycle through the recorded performance in the following order: '0 – 60', '1/4', 'ODO', and 'CAL'.
3. While 'CAL' is displayed, quickly *tap* the push-button once. This will put the speedometer in Program Mode. If you did not tap while 'CAL' is displayed, the pulses per mile will be displayed on the odometer and the display will go back to MPH mode. Otherwise, you will now see 'CAL' displayed along with the number '0'. This indicates that the microprocessor is now ready for calibration.
4. When you are ready, begin driving on the metered mile. You will notice the reading will start counting up. The odometer will begin to display the incoming pulse count. Drive the vehicle through the measured mile (speed is not important, only the distance traveled).
5. At the end of the mile, stop and press the push-button again. The odometer will now display the new number of speedometer pulses that were registered over the distance. The odometer will continue to display the pulse reading for a few seconds. Once it reverts to the default mode, you have successfully calibrated your speedometer.

Warning: If, while in 'CAL' mode, you do not move the vehicle and press the button again, the microprocessor will NOT have received any data and the unit will display 'Err' and will revert to the factory settings. At a minimum, drive some distance and return to the start if necessary. If you miss stopping the display at 'CAL', simply repeat the steps.

Trip Distance

A single *tap* of the recall button will activate the trip meter in the odometer display. A decimal point will appear to indicate that you are in trip meter mode. *Holding* the recall button will clear out the trip distance. To return to the default odometer display, *tap* the recall button again. The decimal point will disappear, indicating that you are back in the default odometer display.

Setting the Odometer

While scrolling through 'CAL' mode you will see 'ODO' appear. This will allow you to enter the vehicle's actual mileage. Press the trip button again at this point and you will enter the odometer set up mode. Press quickly to change the number of the digit on the right. Press and hold to advance to the next digit. Do this for all 5 digits. **For Example:** To enter the mileage reading 23456 into the odometer, at the 'ODO' prompt, tap the small black button (quickly) two times, until the number **2** is displayed. Then press and hold the button until the numbers **20** are displayed. Tap the button 3 times until **23** is displayed. Press and hold the button until **230** is displayed, and continue in this manner until **23456** is displayed. The speedometer will advance to the home screen, five seconds after the last number is entered.

Recording and Viewing Performance Data

Follow these steps to record and recall Performance Data (high speed, $\frac{1}{4}$ mile ET, and 0-60 time):

1. Before each run, your car must be at a complete stop at the starting position. *Press and hold* the push-button as it cycles through the performance data. At the end, the odometer will reset and all performance data will be cleared. This will not affect your stored calibration value or the odometer reading.
2. Press the push-button until 'HI-SP' is displayed. The gauge will automatically cycle through the performance data.
3. Start the run, pass, session, etc., as mentioned above.
4. When finished, repeat *Step 2* to view the data gathered from the run. While stopped, you can view this data as often as you wish. However, once it finishes scrolling one time, the memory is ready to record new data and will begin recording again once the vehicle starts to move. The highest speed measured over multiple runs will be retained in memory.

Made in America

Lifetime Guarantee



Technical Support

Monday – Friday 9am to
5 pm EST

(440) 210-7646 support@intellitronix.com



**This product carries a limited Lifetime Warranty.
This warranty is limited to replacement or repair of the unit at the discretion of Intellitronix.**